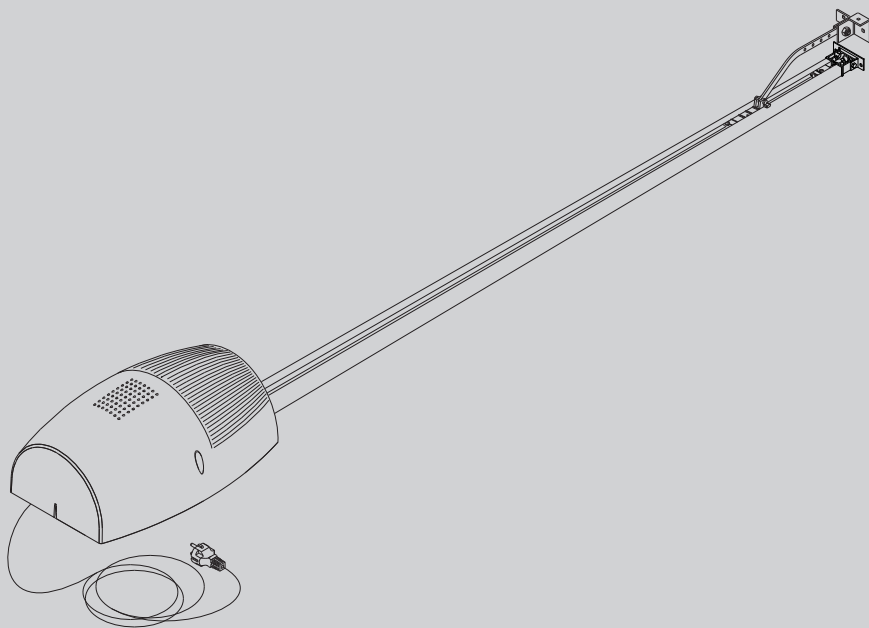




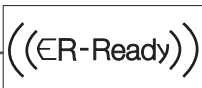
D811526 00100_02 23-12-11

AUTOMAZIONI PER PORTE BASCULANTI E SEZIONALI
AUTOMATION FOR OVERHEAD AND SECTIONAL GARAGE DOORS
AUTOMATION POUR PORTES BASCULANTES ET SECTIONALES
GARAGENTORANTRIEB FÜR SCHWING UND SEKTIONALTORE
AUTOMATIZACIONES PARA PUERTAS BASCULANTE Y SECCIONALES
AUTOMATISERINGEN VOOR KANTEL- EN SECTIEDEUREN



EOS 120 VENERE D

ISTRUZIONI D'USO E DI INSTALLAZIONE
INSTALLATION AND USER'S MANUAL
INSTRUCTIONS D'UTILISATION ET D'INSTALLATION
INSTALLATIONS-UND GEBRAUCHSANLEITUNG
INSTRUCCIONES DE USO Y DE INSTALACION
GEBRUIKS- EN INSTALLATIEAANWIJZINGEN



AZIENDA CON SISTEMA DI GESTIONE
INTEGRATO CERTIFICATO DA DNV
= UNI EN ISO 9001:2008 =
UNI EN ISO 14001:2004

Attenzione! Leggere attentamente le "Avvertenze" all'interno! **Caution!** Read "Warnings" inside carefully! **Attention!** Veuillez lire attentivement les Avertissements qui se trouvent à l'intérieur!
Achtung! Bitte lesen Sie aufmerksam die „Hinweise“ im Inneren! **¡Atención!** Leer atentamente las "Advertencias" en el interior! **Let op!** Lees de "Waarschuwingen" aan de binnenkant zorgvuldig!

Thank you for buying this product, our company is sure that you will be more than satisfied with the product's performance. The product is supplied with a "Warning" leaflet and an "Instruction booklet". These should both be read carefully as they provide important information about safety, installation, operation and maintenance. This product complies with the recognised technical standards and safety regulations. We declare that this product is in conformity with the following European Directives: 2004/108/CE, 2006/95/CE, 2006/42/EEC, 99/05/EEC (and subsequent amendments).

1) GENERAL OUTLINE

The **EOS 120** system is compatible with the **EELink** protocol for fast installation and maintenance. It is suitable for motorising sectional doors, protruding fully retracting spring operated overhead doors and counterweight overhead doors provided with an appropriate towing arm. The overhead door must not be higher than 3 metres. It is easy to install and fast to fit and does not need the door to be modified. The irreversible gearmotor keeps the door locked in the closing position. The control unit is builtin. It controls the operation relays and the safety devices (photocell, rubber skirt) before performing every manoeuvre.

This product was designed to motorise the types of door mentioned above. Any other use is considered contrary to that intended by the manufacturer who, therefore, cannot be held responsible for any injuries to persons or animals, or damage to things which might derive from misuse.

2) SAFETY

If correctly installed and used, this automation device satisfies the required safety level standards. However, it is advisable to observe some practical rules in order to avoid accidental problems. Before using the automation device, carefully read the operation instructions and keep them for future reference.

- Keep children, persons and things outside the automation working area, particularly during operation.
- Keep radio control or other control devices out of children's reach, in order to avoid any unintentional automation activation.
- Do not intentionally oppose the leaf movement.
- Do not attempt to open the door manually, if the internal locking system has not been released by pulling the appropriate wire connected to the carriage (fig.1), or the external lock (**SM1** or **SET/S** fig.2-fig.3) activated.

- Do not modify the automation components.
- In case of malfunction, disconnect the power supply, activate the emergency release to gain access to the automation device and request the assistance of a qualified technician (installer).
- Before proceeding to any external cleaning operation, disconnect the mains powers supply.
- Keep the photocell optical components and luminous signal indication devices clean. Check that the safety devices (photocells) are not obscured by branches or shrubs.
- For any direct assistance to the automation system, request the assistance of a qualified technician (installer).
- Have qualified personnel check the automation system once a year.
- Check the installation frequently, in particular cables, springs and supports to find out any unbalance, sign of wear or damage. Do not use the operator in the case where any repairs or adjustments are required, given that an installation malfunction or an incorrectly balanced door could cause injuries.
- Once a month, check that the motor reverses when encountering an obstacle 50 mm away from the floor. Should operation show to be incorrect, request the assistance of a qualified technician, given that an incorrect adjustment could be dangerous.

3) EMERGENCY MANOEUVRE

In case of electric power failure or system malfunction, the manoeuvre must be carried out manually by pulling the wire connected to the carriage, as in fig.1. For garages which are not provided with a second exit, it is compulsory to fit an external key release device like Mod. **SM1** (fig.2) or Mod. **SET/S** (fig.3).

WARNING: If the door is not correctly balanced, activation of the carriage manual release could provoke an uncontrolled door movement.

4) BULB REPLACEMENT

To replace the courtesy light bulb, remove its transparent cover (fig.4).

WARNING: Only 24V 25W max E14 bulbs must be used.

Fig. 1

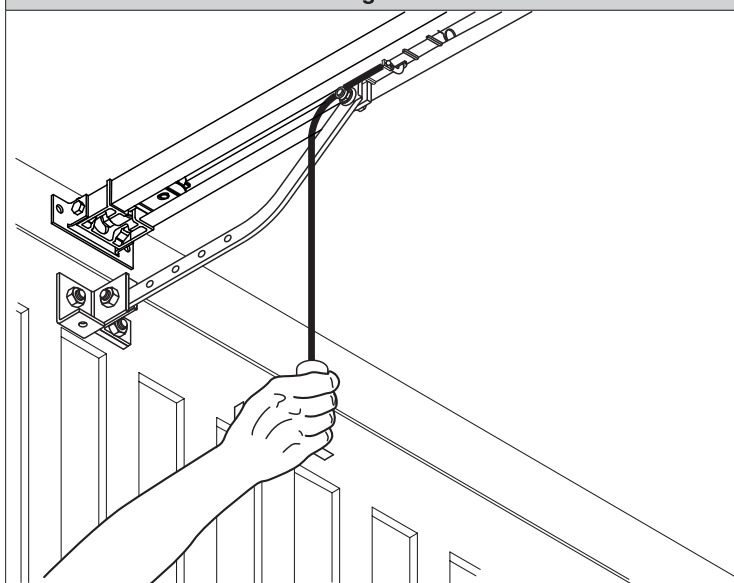


Fig. 2

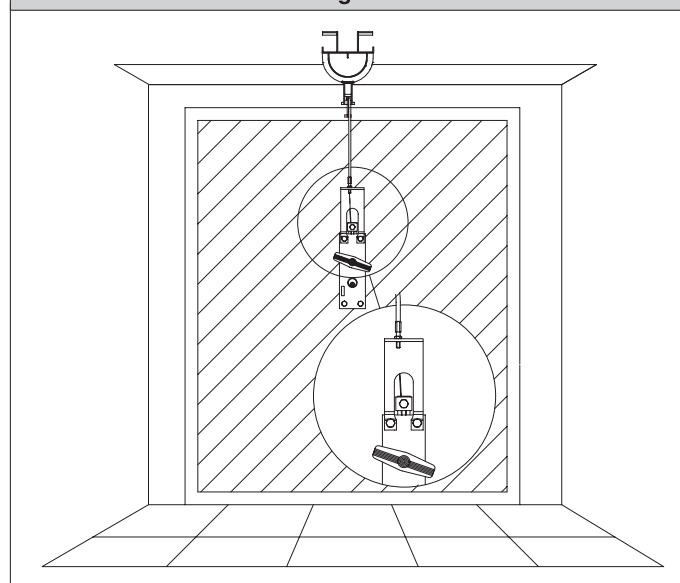


Fig. 3

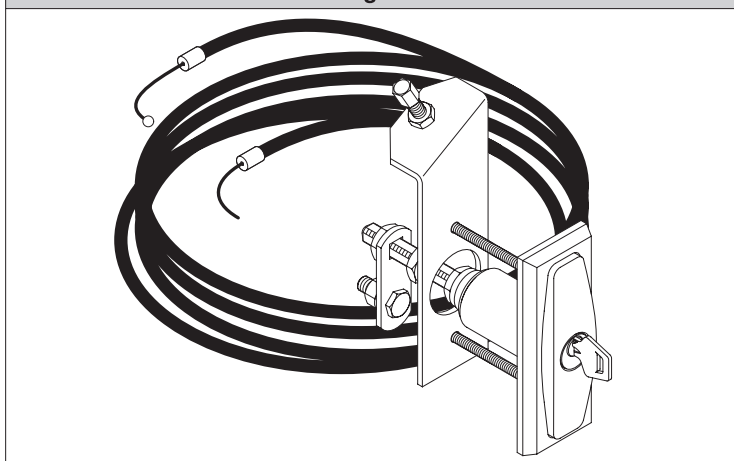
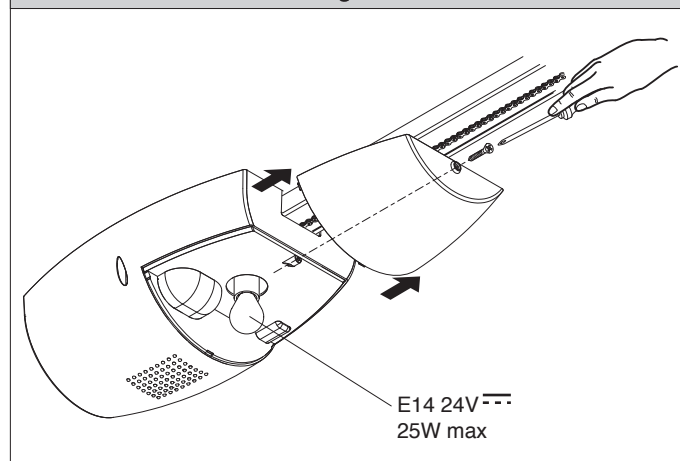


Fig. 4



E14 24V $\overline{\text{---}}$
25W max

INSTALLER WARNINGS

WARNING! Important safety instructions. Carefully read and comply with all the warnings and instructions that come with the product as incorrect installation can cause injury to people and animals and damage to property. The warnings and instructions give important information regarding safety, installation, use and maintenance. Keep hold of instructions so that you can attach them to the technical file and keep them handy for future reference.

GENERAL SAFETY

This product has been designed and built solely for the purpose indicated herein. Uses other than those indicated herein might cause damage to the product and create a hazard.

- The units making up the machine and its installation must meet the requirements of the following European Directives, where applicable: 2004/108/EC, 2006/95/EC, 2006/42/EC, 89/106/EC, 99/05/EC and later amendments. For all countries outside the EEC, it is advisable to comply with the standards mentioned, in addition to any national standards in force, to achieve a good level of safety.
- The Manufacturer of this product (hereinafter referred to as the "Firm") disclaims all responsibility resulting from improper use or any use other than that for which the product has been designed, as indicated herein, as well as for failure to apply Good Practice in the construction of entry systems (doors, gates, etc.) and for deformation that could occur during use.
- Installation must be carried out by qualified personnel (professional installer, according to EN 12635), in compliance with Good Practice and current code.
- Before commencing installation, check the product for damage.
- Before installing the product, make all structural changes required to produce safety gaps and to provide protection from or isolate all crushing, shearing and dragging hazard areas and danger zones in general. Check that the existing structure meets the necessary strength and stability requirements.
- The Firm is not responsible for failure to apply Good Practice in the construction and maintenance of the doors, gates, etc. to be motorized, or for deformation that might occur during use.
- Make sure the stated temperature range is compatible with the site in which the automated system is due to be installed.
- Do not install this product in an explosive atmosphere: the presence of flammable fumes or gas constitutes a serious safety hazard.
- Disconnect the electricity supply before performing any work on the system. Also disconnect buffer batteries, if any are connected.
- Before connecting the power supply, make sure the product's ratings match the mains ratings and that a suitable residual current circuit breaker and overcurrent protection device have been installed upline from the electrical system. Have the automated system's mains power supply fitted with a switch or omnipolar thermal-magnetic circuit breaker with a contact separation that meets code requirements.
- Make sure that upline from the mains power supply there is a residual current circuit breaker that trips at no more than 0.03A as well as any other equipment required by code.
- Make sure the earth system has been installed correctly: earth all the metal parts belonging to the entry system (doors, gates, etc.) and all parts of the system featuring an earth terminal.
- Installation must be carried out using safety devices and controls that meet standards EN 12978 and EN 12453.
- Impact forces can be reduced by using deformable edges.
- In the event impact forces exceed the values laid down by the relevant standards, apply electro-sensitive or pressure-sensitive devices.
- Apply all safety devices (photocells, safety edges, etc.) required to keep the area free of impact, crushing, dragging and shearing hazards. Bear in mind the standards and directives in force, Good Practice criteria, intended use, the installation environment, the operating logic of the system and forces generated by the automated system.
- Apply all signs required by current code to identify hazardous areas (residual risks). All installations must be visibly identified in compliance with the provisions of standard EN 13241-1.
- This product cannot be installed on leaves incorporating doors (unless the motor can be activated only when the door is closed).
- If the automated system is installed at a height of less than 2.5 m or is accessible, the electrical and mechanical parts must be suitably protected.
- Install any fixed controls in a position where they will not cause a hazard, away from moving parts. More specifically, hold-to-run controls must be positioned within direct sight of the part being controlled and, unless they are key operated, must be installed at a height of at least 1.5 m and in a place where they cannot be reached by the public.
- Apply at least one warning light (flashing light) in a visible position, and also attach a Warning sign to the structure.
- Attach a label near the operating device, in a permanent fashion, with information on how to operate the automated system's manual release.
- Make sure that, during operation, mechanical risks are avoided or relevant protective measures taken and, more specifically, that nothing can be banged, crushed, caught or cut between the part being operated and surrounding parts.
- Once installation is complete, make sure the motor automation settings are correct and that the safety and release systems are working properly.
- Only use original spare parts for any maintenance or repair work. The Firm disclaims all responsibility for the correct operation and safety of the automated system if parts from other manufacturers are used.
- Do not make any modifications to the automated system's components unless explicitly authorized by the Firm.
- Instruct the system's user on what residual risks may be encountered, on the control systems that have been applied and on how to open the system manually in an emergency. Give the user guide to the end user.
- Dispose of packaging materials (plastic, cardboard, polystyrene, etc.) in accordance with the provisions of the laws in force. Keep nylon bags and polystyrene out of reach of children.

WIRING

WARNING! For connection to the mains power supply, use: a multicore cable with a cross-sectional area of at least $5 \times 1.5 \text{ mm}^2$ or $4 \times 1.5 \text{ mm}^2$ when dealing with three-phase power supplies or $3 \times 1.5 \text{ mm}^2$ for single-phase supplies (by way of example, type H05 VV-F cable can be used with a cross-sectional area of $4 \times 1.5 \text{ mm}^2$). To connect auxiliary equipment, use wires with a cross-sectional area of at least 0.5 mm^2 .

- Only use pushbuttons with a capacity of 10A-250V or more.
- Wires must be secured with additional fastening near the terminals (for example, using cable clamps) in order to keep live parts well separated from safety extra low voltage parts.
- During installation, the power cable must be stripped to allow the earth wire to be connected to the relevant terminal, while leaving the live wires as short as possible. The earth wire must be the last to be pulled taut in the event the cable's fastening device comes loose.

WARNING! safety extra low voltage wires must be kept physically separate from low voltage wires.

Only qualified personnel (professional installer) should be allowed to access live parts.

CHECKING THE AUTOMATED SYSTEM AND MAINTENANCE

Before the automated system is finally put into operation, and during maintenance work, perform the following checks meticulously:

- Make sure all components are fastened securely.
- Check starting and stopping operations in the case of manual control.
- Check the logic for normal or personalized operation.
- For sliding gates only: check that the rack and pinion mesh correctly with 2 mm of play; keep the track the gate slides on clean and free of debris at all times.
- Check that all safety devices (photocells, safety edges, etc.) are working properly and that the anti-crush safety device is set correctly, making sure that the force of impact measured at the points provided for by standard EN 12445 is lower than the value laid down by standard EN 12453.
- Impact forces can be reduced by using deformable edges.
- Make sure that the emergency operation works, where this feature is provided.
- Check opening and closing operations with the control devices applied.
- Check that electrical connections and cabling are intact, making extra sure that insulating sheaths and cable glands are undamaged.
- While performing maintenance, clean the photocells' optics.
- When the automated system is out of service for any length of time, activate the emergency release (see "EMERGENCY OPERATION" section) so that the operated part is made idle, thus allowing the gate to be opened and closed manually.
- If the power cord is damaged, it must be replaced by the manufacturer or their technical assistance department or other such qualified person to avoid any risk.
- If "D" type devices are installed (as defined by EN 12453), connect in unverified mode, foresee mandatory maintenance at least every six months

SCRAPPING

Materials must be disposed of in accordance with the regulations in force. There are no particular hazards or risks involved in scrapping the automated system. For the purpose of recycling, it is best to separate dismantled parts into like materials (electrical parts - copper - aluminium - plastic - etc.).

DISMANTLING

If the automated system is being dismantled in order to be reassembled at another site, you are required to:

- Cut off the power and disconnect the whole electrical system.
- Remove the actuator from the base it is mounted on.
- Remove all the installation's components.
- See to the replacement of any components that cannot be removed or happen to be damaged.

Anything that is not explicitly provided for in the installation manual is not allowed. The operator's proper operation can only be guaranteed if the information given is complied with. The Firm shall not be answerable for damage caused by failure to comply with the instructions featured herein.

While we will not alter the product's essential features, the Firm reserves the right, at any time, to make those changes deemed opportune to improve the product from a technical, design or commercial point of view, and will not be required to update this publication accordingly.

2) GENERAL OUTLINE

The EOS 120 system is suitable for motorising sectional doors (fig. 3), protruding fully retracting spring-operated overhead doors (fig. 2) and counterweight overhead doors provided with an appropriate towing arm (fig. 4). The overhead door must not be higher than 3 metres. Its easy installation allows fast fitting without needing the door to be modified. The irreversible gearmotor keeps the door locked in the closing position.

3) TECHNICAL SPECIFICATIONS

3.1) Actuator

Power supply:	230V~ ±10%, 50/60Hz single-phase (*)
Motor voltage:	24V~
Max. power absorbed from mains:	236W
Lubrication:	permanent grease
Towing and pushing force:	1200N
Working stroke:	TRACK L.=2900 working stroke=2400 mm(**)
	TRACK L.=3500 working stroke=3000 mm(***)
Average speed:	4,5 m/min
Impact reaction:	integrated torque limiter on control panel
Manoeuvres in 24 hours:	100
Limit switch:	Electronic with ENCODER
Courtesy light:	24V~ 25W max, E14 bulb
Working temperature:	-15°C / +60°C
Degree of protection:	IPX0
Motor head weight:	5 kg
Noise level:	<70dB(A)
Dimensions:	see fig.1

(*) Available in all mains voltages.

(**) By turning the motor head by 90° (Fig.11) the useful stroke will be 2580 mm.

(***) By turning the motor head by 90° (Fig.11) the useful stroke will be 3180 mm.

4) ACTUATOR INSTALLATION

4.1) Preliminary checks

- Check that the door is balanced.
- Check that the door slides smoothly along its entire travel.
- If the door has not been newly installed, check the wear condition of all its components.
- Repair or replace faulty or worn parts.
- The automation reliability and safety are directly influenced by the state of the door structure.
- Before fitting the motor, remove any superfluous ropes or chains and disable any unnecessary appliances.

4.2) FITTING

After unpacking, dispose of the parts which make up the package properly, by separating the different type of materials (cardboard, polystyrene, PVC, etc.) according to the national rules in force.

- 1) Remove the existing locking bolt from the cremone bolt of the door.
- 2) Fit the metal wall bracket to the track-holder bracket using the screws supplied as standard (Fig.12 Ref.E). The screws must not be tightened, so that the bracket can be rotated.
- 3) In order for the track to be correctly fixed, mark the mid-point of the door, position the BIN onto the ceiling and mark the holes (Fig.6).
Make sure that the distance between the track and the door panel is comprised between 108 and 166 mm (see Fig.14). If this is not the case, use the brackets provided (Fig.10). If the distance is smaller, the towing plate must be shortened.
- 4) Drill the ceiling using a D.10 bit, with reference to the markings made previously, and insert the plugs.
- 5) With the help of an adequate support, lift the entire motor, screw the screws onto the track-holding bracket without fixing them to the door frame (Fig.9A) or, if the height allows it, fit the bracket to the masonry lintel by means of plugs (Fig.9B).
- 6) Rest the motor onto the floor (taking care not to damage it) and fix the articulated bracket to the door frame or to the ceiling (Fig.9A, Fig.9B).
- 7) Lift the motor-driven head until everything rests against the ceiling and insert the fixing screws which lock the track.
- 8) In the case where the motor is not directly fixed to the ceiling, fit the brackets as shown in Fig.10 Ref.C, after marking and drilling the holes with reference to the brackets.
- 9) In the case where the track is made in two halves, see Fig.13; for the different types of fixing methods, see the previous figures.
- 10) Release the carriage and fix the anchoring brackets to the door panel (Fig.14). The distance allowed between track and sectional door is 108 to 166 mm. In case of greater distance, it is necessary to use the brackets and lower the motor; in case of shorter distance, it is necessary to shorten the towing plate.
- 11) Check that the carriage and anchoring bracket screws provide for correct play of the towing bar.
- 12) Stick the adhesive labels supplied next to the dangerous points (Fig. 5).

5) CHAIN TIGHTENER ADJUSTMENT (EOS 120)

The operator supplied is already calibrated and inspected. Should the chain tension need to be adjusted, proceed as shown in fig. 15.

WARNING: the anti-tear spring element must never be completely compressed. Scrupulously check that the spring does not become totally compressed during operation.

6) ELECTRICAL INSTALLATION SET-UP (Fig.16)

M) Actuator

Ft) Transmitter photocell

Fr) Receiver photocells

T) 1-2-4 channel transmitter.

Arrange for the connections of accessories and safety and control devices to reach the motor unit, keeping the mains voltage connections clearly separate from the extra low safety voltage connections (24V) by means of the appropriate cable holder (fig. 8 ref. 5P1).

Proceed to connection following the indications given in the wiring diagram.

The cables for connecting the accessories must be protected by a raceway (fig. 8 ref. 5C1).

7) VENERE D Control panel (Fig.17)

Supply to accessories:	24V~ (180mA max)
	24V~ Vsafe VENERE D (180mA max)
Torque limiter setting:	on closing and opening
Automatic closing time:	from 1 to 180s
Blinker connection:	24V~ max 25W
Service light switching-on time:	90s
Incorporated rolling-code radio receiver:	frequency 433.92 MHz
Coding:	rolling-code algorithm
No. combinations:	4 milliard
Antenna impedance:	50Ohm (RG58)
Max no. radio controls to be memorised:	10
Fuses:	see figure 17

7.1) Terminal board connections (Fig.17)

WARNINGS - For wiring and installation operations, refer to the current standards and good technical principles.

The wires supplied with extra low safety voltage (24V) must be kept physically separate from the low voltage wires, or else they must be provided with adequate additional insulation of at least 1mm.

The wires must be clamped by an extra fastener near the terminals, for example by bands.

TERMINAL	DESCRIPTION
JP2	transformer wiring
JP10	motor wiring
1-2	Antenna input for integrated radio-receiver board (1: BRAID. 2: SIGNAL)
3-4	START input (N.O.)
3-5	STOP input (N.C.) If not used, leave the jumper inserted.
3-6	PHOTOCELL input (N.C.) If not used, leave the jumper inserted.
3-7	FAULT input (N.O.) Input for photocells provided with checking N.O. contact
8-9	24 V~ output for blinking light (25 W max)
10-11	24V~ 180mA max output – power supply for photocells or other devices
12-13	24V~ Vsafe 180mA max output – power supply for checking photocell transmitters.
16-17	PARTIAL OPENING input

8) PROGRAMMING

The control panel with built-in microprocessor comes with factory settings, which are valid for standard installations. The preset parameters can only be edited using the built-in programmer with display or universal handheld programmer. If you are performing programming via a universal handheld programmer, carefully read the relevant instructions for use of the universal handheld programmer before proceeding as follows. Connect the universal handheld programmer to the control unit by means of the UNIFLAT accessory. Enter the "CONTROL UNITS" menu, then the "PARAMETERS" submenu and use the up/down arrows to run through the screens on the display, entering the numerical values of the parameters listed below.

For information on operating logics, refer to the "LOGIC" submenu.

If you are performing programming with the aid of the built-in programmer, refer to Fig. A and B and to the "setup" section.

The meaning of each parameter and the values each can be given are listed below.

8.1) Setup

Via the programmer with display, you can set all the VENERE D control panel's functions.

The programmer has three buttons for navigating between menus and setting operating parameters:

+ menu scroll/increase value key

- menu scroll/decrease value key

OK return key (confirm).

Pressing the + and - keys at the same time allows you to exit the menu you are working inside and move to the next menu up. If the + and - keys are pressed at the same time when on the main menus (parameters-logic-radio-language-default-autoset-limit switch adjustment), you exit programming and the display switches off (the END message appears).

Changes only become operative if the OK key is pressed after they are made. The first time you press the OK key, you enter programming mode.

To start with, the display gives the following information:

- Software version of control unit
- Total number of operations carried out (the value is given in thousands, hence the display will keep showing 0000 for the first thousand operations)
- Number of operations carried out since last service (the value is given in thousands, hence the display will keep showing 0000 for the first thousand operations)
- Number of memorized remote controls.

Pressing the OK key during the initial presentation allows you to skip to the first menu (parameters-logic-radio-language-default-autoset-limit switch adjustment). The main menus are listed below along with the relevant submenus available for each.

The default setting is the one inside square brackets [0]

The message that appears on the display is shown inside round brackets.

Refer to Figures A and B for the control unit setup procedure.

8.2) Parameters Menu (PAR AM)

- Automatic Closing Time (LcR) [40s]

Set the numerical value of the automatic opening time in the range 1 to 180 seconds.

- Opening torque (OP L or 9UE) [50%]

Set the numerical value of the motor's opening torque in the range 1% to 99%.

- Closing torque (cL SŁor 9UE) [50%]

Set the numerical value of the motor's closing torque in the range 1% to 99%.
NOTE: In case of obstacle detection, the Ampere-stop function halts the leaf movement, reverses the motion for 1 sec. and stays in the STOP state.

WARNING: Check that the force of impact measured at the points provided for by standard EN 12445 is lower than the value laid down by standard EN 12453.

Setting sensitivity incorrectly can result in damage to property and injury to people and animals.

- Partial opening (PRrŁoPEn) [1.0 m]

Set the numerical value of partial opening in the range 10 cm (0.001) to 6 m (006.0)

- Zone (ZonE) [0]

Set the zone number between a minimum value of 0 and a maximum value of 127. See section 11 entitled "Serial connection".

- Running speed during opening (oP SPEEd) [99%]

Sets the maximum opening speed reached by the actuator at running speed. The value is given as a percentage of the maximum speed the actuator can reach.

- Running speed during closing (cL SPEEd) [99%]

Sets the maximum closing speed reached by the actuator at running speed. The value is given as a percentage of the maximum speed the actuator can reach.

- Slow-down distance (d SŁŁoŁd) [007]

Sets the slow-down distance travelled by the actuator during opening and closing. The value is given in centimetres.

WARNING! Editing one of the following parameters:

- Running speed during opening
- Running speed during closing
- Slow-down distance

results in the actuator performing a complete opening/closing cycle with the anti-crush feature switched off. The "SET" message flashes on the display to warn that this cycle is in progress.

8.3) LOGIC MENU (ŁoŁ ıC)

- Automatic Closing Time (ŁcR) [OFF]

ON: Switches automatic closing on

OFF: Switches automatic closing off

- 3 Step (3 Step) [OFF]

ON: Switches to 3-step logic.

A start pulse has the following effects:
 door closed:.....opens during opening:.....stops and switches on TCA (if configured)
 door open:.....closes during closing:.....stops and movement is reversed after stop:.....opens

OFF: Switches off 3-step logic.

- Block opening pulses (ıbŁ oPEn) [OFF]

ON: The start pulse has no effect during opening.

OFF: The start pulse has effect during opening.

- Pre-alarm (PrE -RŁRrŁ) [OFF]

ON: The flashing light comes on approx. 3 seconds before the motor starts.

OFF: The flashing light comes on at the same time as the motors start.

- Photocells during opening (PhoŁoŁoPEn) [OFF]

ON: when beam is broken, operation of the photocell is switched off during opening. During closing, movement is reversed immediately.

OFF: when beam is broken, photocells are active during both opening and closing. When beam is broken during closing, movement is reversed only once the photocell is cleared.

- Photocell test (ŁE SŁ PhoŁ) [OFF]

ON: Switches photocell testing on (see fig. 17A)

OFF: Switches photocell testing off

- Gate open light or 2nd radio channel (ScR Łch) [ON]

ON: The output between terminals 14-15 is set as Gate open light: in this case, the 2nd radio channel controls partial opening.

OFF: The output between terminals 14-15 is set as 2nd radio channel.

- Fixed Code (F ŁŁEd ŁodE) [OFF]

ON: Receiver is configured for operation in fixed-code mode, see "Radio transmitter cloning" section.

OFF: Receiver is configured for operation in rolling-code mode, see "Radio transmitter cloning" section.

- Remote control programming (RŁd ıo PrŁoŁ) [ON]

ON: Enables wireless memorizing of transmitters (Fig.20):

- 1- Press in sequence the hidden key (P1) and normal key (T1-T2-T3-T4) of a transmitter that has already been memorized in standard mode via the radio menu.
- 2- Press within 10 sec. the hidden key (P1) and normal key (T1-T2-T3-T4) of a transmitter to be memorized.

The receiver exits programming mode after 10 sec.: you can use this time to enter other new transmitters.

This mode does not require access to the control panel.

OFF: Disables wireless memorizing of transmitters. Transmitters are memorized only using the relevant Radio menu.

- START - OPEN setting (SŁRrŁ -oPEn) [OFF]

ON: Input between terminals 3-4 works as OPEN.

OFF: Input between terminals 3-4 works as START.

- PED-CLOSE setting (PEd -cŁoSE) [OFF]

ON: Input between terminals 16-17 works as CLOSE.

OFF: Input between terminals 16-17 works as PARTIAL OPENING.

- Master/Slave (ŁRSŁEr) [OFF]

ON: Control panel is set up as the Master unit in a centralized connection system.

OFF: Control panel is set up as a Slave unit in a centralized connection system.

8.4) RADIO MENU (rŁd ıo)

- Add

Used to add a key on a remote control to the receiver's memory. Once memorized, it returns the number of the receiver in the memory location (from 01 to 64).

- Add Start Key (RŁd SŁRrŁ)

associates the desired key with the Start command

- Add 2ch Key (RŁd Łch)

associates the desired key with the 2nd radio channel command

- Read (rŁRd)

Checks a key of a receiver and, if memorized, returns the number of the receiver in the memory location (from 01 to 64) and number of the key (T1-T2-T3 or T4).

- Erase List (ErRSE EŁ)

WARNING! Erases all memorized remote controls from the receiver's memory.

- Read receiver code (Łod rŁ)

Displays the code entered in the receiver.

- W LINK (ŁŁŁ)

ON =

Enables remote programming of cards via a previously memorized W LINK remote control. It remains enabled for 3 minutes from the time the W LINK remote control is last pressed.

Refer to the W LINK remote control's manual for the mapping of the relevant keys.

OFF =

W LINK programming disabled.

Consult sections 8/9/10/11 for further information on the built-in Clonix receiver's advanced features.

8.5) LANGUAGE MENU (ŁRnŁŁRŁŁE)

Used to set the programmer's language on the display.

There are 5 language options:

- ITALIAN (ıŁŁ)
- FRENCH (FrŁ)
- GERMAN (ŁEŁ)
- ENGLISH (ErŁŁ)
- SPANISH (ESŁ)

8.6) DEFAULT MENU (ŁEFFRŁŁŁŁ)

Restores the controller's default factory settings. Following this reset, you will need to run the autosest function again.

8.7) DIAGNOSTICS AND MONITORING

The display on the **VENERE D** panel gives a certain amount of useful information both during normal operation and when faults are detected.

Diagnostics:

In the event of malfunctions, the display gives a message showing which device needs checking:

- STRT = START input activated
- STOP = STOP input activated
- PHOT = PHOT input activated
- SWO = OPENING LIMIT SWITCH input activated
- SWC = CLOSING LIMIT SWITCH input activated
- PED = PEDESTRIAN input activated
- OPEN = OPEN input activated
- CLS = CLOSE input activated

In the event the door encounters an obstacle, the **VENERED** panel stops the door and commands it to reverse, while on the display the "AMP" message appears

Monitoring:

During opening and closing, the display shows four numbers separated by a decimal point, e.g. 35.40. The numbers are updated constantly during the door's operation and stand for the instantaneous torque reached by motor 1 (35) and torque threshold (opening, closing, slow-down) set in the parameters menu (40). Via these values, we can correct the torque setting.

If the value of the instantaneous torque reached during the door's operation gets rather close to the threshold value set in the parameters menu, malfunctioning may occur in the future due to wear or the door becoming slightly misshapen. Consequently, it is advisable to check the maximum torque reached during a number of cycles at the installation stage and, where necessary, set a value approx. 5/10 percentage points higher in the parameters menu.

8.8) ERROR DIAGNOSTICS:

- ER01** Error in safety device (photocell) test
- ER10** Problems detected in motor's control circuit
- ER11** Problems detected in motor's current reading circuit

8.9) AUTOSSET MENU

- Move the door to the closed position
- Launch an autosest operation by going to the relevant menu on the **VENERE D** panel (Fig.B).

As soon as you press the OK button, the "....." message is displayed and the control unit commands the door to perform a full cycle (opening followed by closing), during which the minimum torque value required for the door to move is set automatically.

During this stage, it is important to avoid breaking the photocells' beams and not to use the START and STOP commands or the display.

Once this operation is complete, the control unit will have automatically set the optimum torque values. Check them and, where necessary, edit them as described in the programming section.

WARNING: Check that the force of impact measured at the points provided for by standard EN 12445 is lower than the value laid down by standard EN 12453.

Warning!! While the autosest function is running, the obstacle detection function is not active. Consequently, the installer must

8.10) LIMIT SWITCH ADJUSTMENT MENU

The **VENERE D** control panel has an opening and closing limit switch adjustment menu, which simplifies the installation procedure.

Refer to Figures 18/19 and Fig.B illustrating the control panel's programming and proceed as follows:

- Launch a limit switch adjustment operation by going to the relevant menu on the VENERE D panel (Fig.B).
- When the "CLOSE" message is displayed, move the door to the desired closed position using the "UP" and "DOWN" buttons on the control unit, bearing in mind that the "DOWN" button closes the door, while the "UP" button opens the door. As soon as the door is in the desired closed position, press the "OK" button to store the closed travel limit position.
- When the "OPEN" message is displayed, move the door to the desired open position using the "UP" and "DOWN" buttons on the control unit, bearing in mind that the "DOWN" button closes the door, while the "UP" button opens the door. As soon as the door is in the desired open position, press the "OK" button to store the open travel limit position.
- Position the "runner stop" correctly up against the runner and secure in place with the screws (fig.18 ref.6 A-B).
NOTE: These operations must be performed in "deadman" mode at reduced speed and without the safety devices operating.

8.11) STATISTICS

Connect the UNIVERSAL HANDHELD programmer to the control unit, enter the CONTROL UNIT/STATISTICS menu and run through the statistics parameters screen:

- Software version of card microprocessor.
- Number of cycles performed. If the motors are replaced, write down the number of operations performed so far.
- Number of cycles performed since last service. Automatically reset every time self-diagnosis is run or parameters are written.
- Date of last service. Must be updated manually via the relevant "Update service date" menu
- System description. Allows for 16 characters to be entered to identify the system.

9) TECHNICAL DATA OF BUILT-IN RECEIVER

Receiver's output channels:

- output channel 1, if activated, commands the door to START
- output channel 2, if activated, commands the 2nd radio channel relay to energize for 1 sec..

Usable transmitter versions:

All ROLLING CODE transmitters compatible with



9.1) INSTALLING THE ANTENNA

Use an antenna tuned to 433MHz.

Use RG58 coax cable to connect the Antenna and Receiver.

Metal bodies close to the antenna can interfere with radio reception. If the transmitter's range is limited, move the antenna to a more suitable position.

9.2) RECEIVER SETUP

Cloning can only be performed with the relevant programmer (UNIRADIO).

The on-board receiver, which is of the cloneable kind, combines the qualities of extreme security with rolling-code copying and the practicality of being able to "clone" transmitters by virtue of an exclusive system.

Cloning a transmitter means generating a transmitter that can get itself entered automatically on the list of transmitters memorized in the receiver either by being added or by replacing a given transmitter.

Replacement cloning can be used to create a new transmitter that takes the place of the previously memorized transmitter in the receiver. With this method, a transmitter can be removed from the memory and be put out of service.

Hence a large number of added transmitters or transmitters replacing lost ones, for example, can be programmed remotely without having physical access to the receiver.

When the security of the code is not crucial, the on-board receiver can be used to add a transmitter via fixed-code cloning: while opting not to use the rolling code, this still gives us a code with a large number of combinations, at the same time we still have the option of "copying" any previously programmed transmitter.

PROGRAMMING

Transmitters can be memorized in manual mode or by means of the UNIRADIO programmer, which allows the installation's complete database to be managed via the EEdbase software.

In the latter case, the receiver is programmed by connecting UNIRADIO to the VENERE D control panel, using the UNIFLAT and UNIDA accessories.

9.3) MANUAL PROGRAMMING

In the case of standard installations in which advanced features are not required, transmitters can be memorized manually, referring to Fig.B for the basic programming.

- If you want the transmitter to activate output 1 (START) with key 1 or key 2 or key 3 or key 4, enter the transmitter in the start key menu as illustrated in Fig.B.
- If you want the transmitter to activate output 2 (2nd radio channel relay) with key 1 or key 2 or key 3 or key 4, enter the transmitter in the 2ch key menu as illustrated in Fig.B.

Note: The hidden key P1 changes appearance depending on the transmitter model. For transmitters featuring a hidden key, press the hidden button P1 (Fig.B1).

For transmitters with no hidden key, simultaneously pressing the transmitter's 4 keys, or opening the battery compartment and using a screwdriver to jump the two P1 points (Fig.B2), is equivalent to pressing key P1.

IMPORTANT NOTE: THE FIRST TRANSMITTER MEMORIZED MUST BE IDENTIFIED BY ATTACHING THE KEY LABEL (MASTER).

In the event of manual programming, the first transmitter assigns the RECEIVER'S KEY CODE: this code is required to subsequently clone the radio transmitters.

9.4) CLONING RADIO TRANSMITTERS

Cloning with rolling code/Cloning with fixed code

Refer to the UNIRADIO instructions and CLONIX programming guide.

9.5) ADVANCED PROGRAMMING: RECEIVER COMMUNITY

Refer to the UNIRADIO instructions and CLONIX programming guide.

9.6) REMOTE TRANSMITTER PROGRAMMING (Fig.20)

- 1) Press the hidden key (P1) of a transmitter that has already been memorized in standard mode via manual programming.

- 2) Press the normal key (T1-T2-T3-T4) of a transmitter that has already been memorized in standard mode via manual programming.
- 3) The courtesy light flashes. Press within 10 sec. the hidden key (P1) of a transmitter to be memorized.
- 4) The courtesy light remains steadily lit. Press the normal key (T1-T2-T3-T4) of a transmitter to be memorized.

The receiver exits programming mode after 10 sec.: you can use this time to enter other new transmitters. This mode does not require access to the control panel.

10) SERIAL CONNECTION VIA SCS1 CARD (Fig.20A)

The VENERE D control panel's special serial inputs and outputs (SCS1) make the centralized connection of a number of automated devices possible. That way, all the automated devices connected can be opened or closed with a single command. Connect all VENERE D control panels using twisted pair cabling only, proceeding as shown in the diagram in Fig.20A.

When using a telephone cable with more than one pair, it is essential to use wires from the same pair.

The length of the telephone cable between one unit and the next must not be greater than 250 m.

At this point, each VENERE D control panel needs to be configured appropriately, starting by entering a MASTER control panel that will have control over all the others, which therefore have to be set as SLAVE units (see logic menu).

Also set the Zone number (see parameters menu) in the range 0 to 127.

The zone number allows you to create groups of automated devices, each of which answers to the Zone Master. **Each zone can have only one Master: the Master of zone 0 also controls the Slaves of the other zones.**

11) EMERGENCY MANOEUVRE

In case of electric power failure or system malfunction, the manoeuvre must be carried out manually by pulling the wire connected to the carriage, as in fig.21. For garages which are not provided with a second exit, it is compulsory to fit an external key release device like Mod. SM1 (fig.22) or Mod. SET/S (fig.23).

12) AUTOMATION CHECK

Before the automation device finally becomes operational, scrupulously check the following conditions:

- Check that all the safety devices (limit microswitches, photocells, electric edges etc) operate correctly.
- Check that the door (antisquash) thrust is comprised within the limits set out by the current standards, and anyway not too strong for the installation and operating conditions.
- Check that the chain-tightening spring element is not completely compressed during the manoeuvre.
- Check the manual opening control operation.
- Check the opening and closing operations using the control devices fitted.
- Check the normal and customised operation electronic logics.

13) AUTOMATION DEVICE USE

- Since the automation device can be remotely controlled by means of a radio control device or a Start button, and therefore when not in sight, all the safety devices must be frequently checked in order to ensure their perfect efficiency. In the event of any malfunction, request immediate assistance from qualified personnel. Children must be kept at a safe distance from the automation operation area.

- Partial or pedestrian opening is to be treated as an operation to be performed only occasionally and no more than 5 such operations should be performed in a row if the automated system is to work properly.

14) AUTOMATION CONTROL

The use of this control device allows the gate to be opened and closed automatically. There are different types of controls (manual, radio control, magnetic card access etc.) depending on the installation requirements and characteristics. For the various control systems, see the relevant instructions. The automation device users must be instructed on control and operation.

15) ACCESSORIES

SM1 External release device to be applied to the cremone bolt already fitted to the overhead door (fig.22).

SET/S External release device with retracting handle for sectional doors measuring max 50mm (fig.23).

ST Automatic bolt release device for spring-operated overhead doors. Fitted to the control arm, it automatically releases the side door bolts (fig.24).

16) MAINTENANCE

Before carrying out any maintenance operation, disconnect the system power supply.

- Periodically check the tension of the chain/belt (twice a year).
- Occasionally clean the photocell optical elements, if installed.
- Have a qualified technician (installer) check the correct setting of the electronic clutch.
- When any operational malfunction is found, and not resolved, disconnect the system power supply and request the assistance of a qualified technician (installer). When the product is out of service, activate the manual release device to allow the door to be opened and closed manually.

⚠ If the power supply cable is damaged, it must be replaced directly by our company or our technical service department or by a technician having similar qualification so as to avoid any risks.

16.1) FUSE REPLACEMENT (Fig.25)

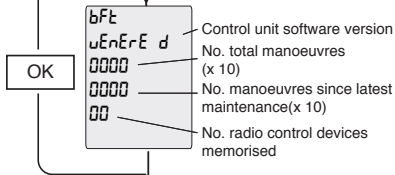
WARNING! Disconnect the mains voltage.

Remove the rubber protection from the fuse-carrier. Remove the fuse (Fig.25, Ref.A) to be replaced and replace it with a new one. After completing this operation, re-fit the rubber protection.

Fig. A

ACCESS TO MENUS

Press the OK key
OK



LEGENDA

[00] Preset value

↑ +/ON
↓ -/OFF Parameter increment/reduction or ON/OFF commutation

OK Press OK key (Enter/confirm)

↓ +↑ Menu scrolling (+ = preceding - = following)

+/- Simultaneously press the + and - keys. Simultaneous pressure of the + and - keys allows you to exit the active menu and return to the preceding menu; if this takes place at the main menu level, programming is exited and the display switched off.

PrG ok OK! message (confirms modification made)

PrG ko KO! message (value or function error)

-< "Wait" message (enter value or function)

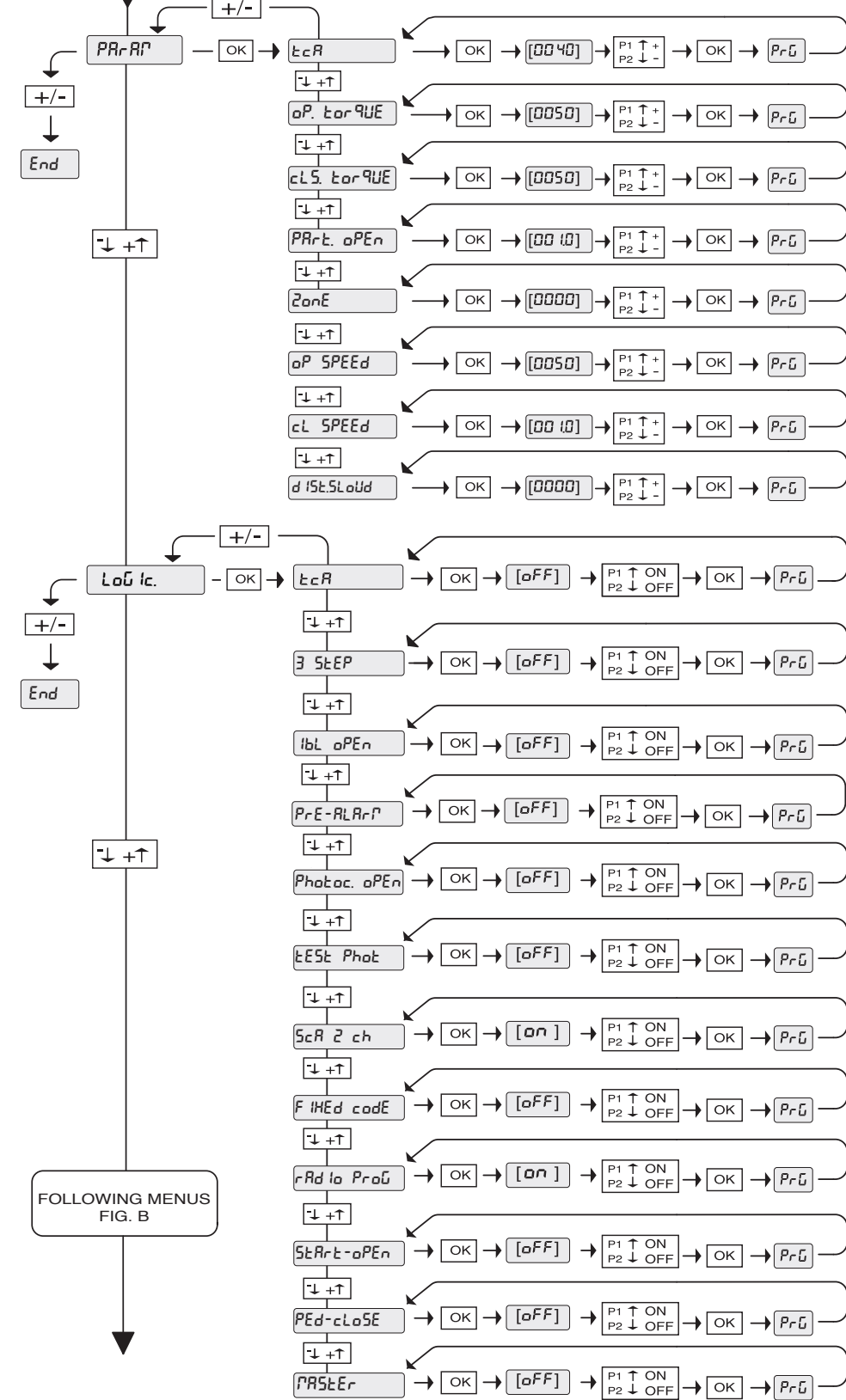
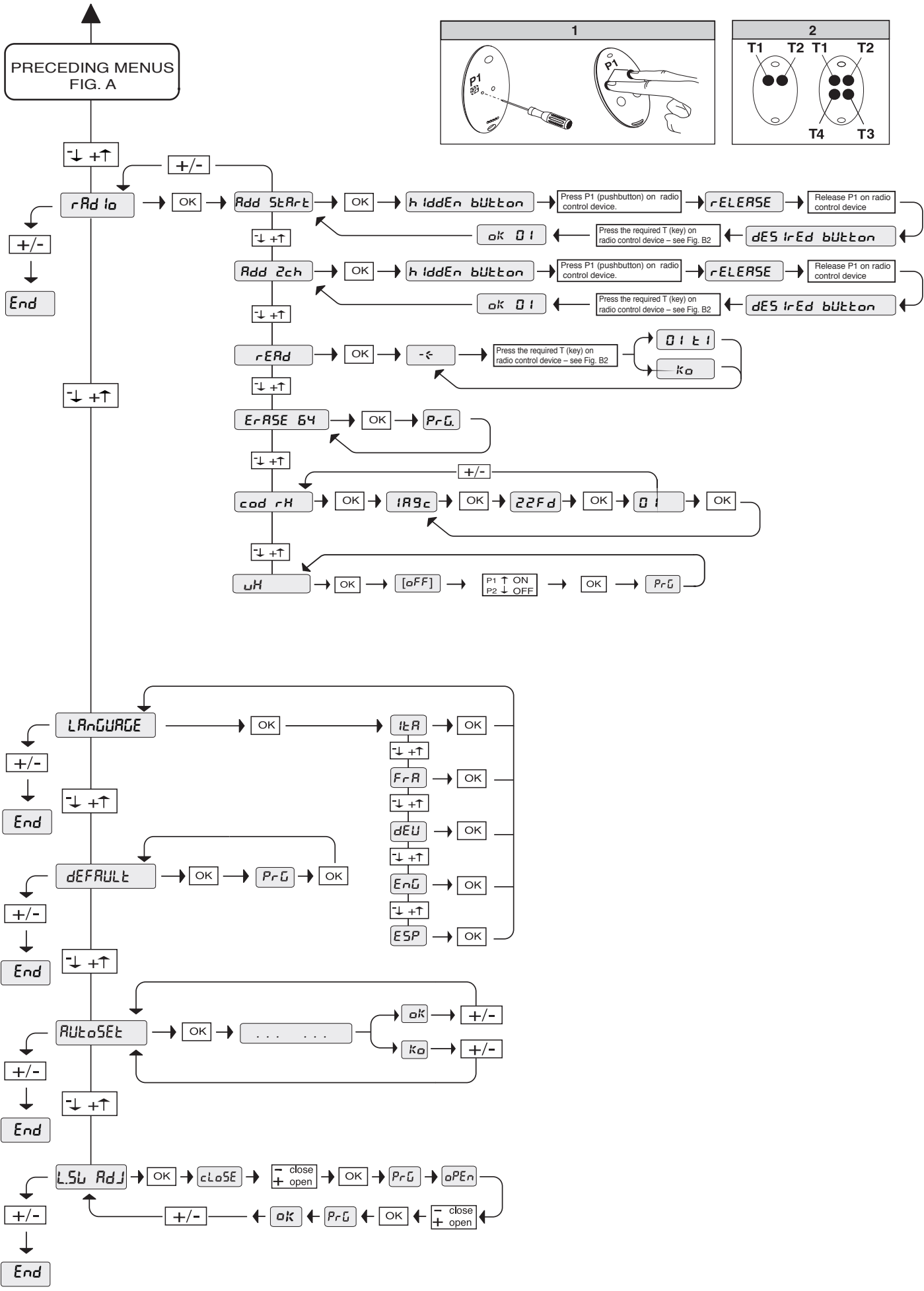
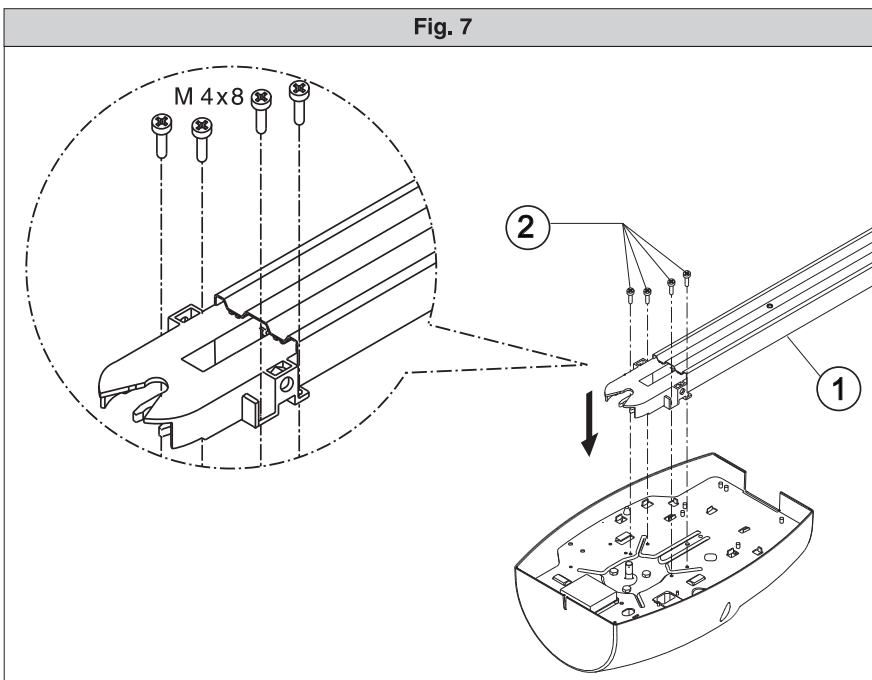
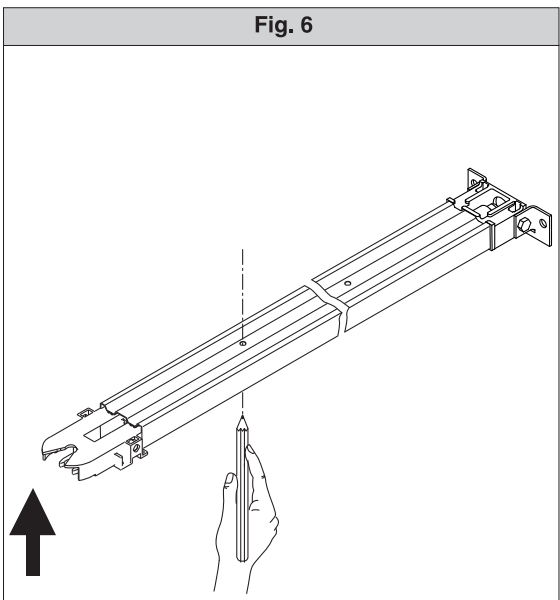
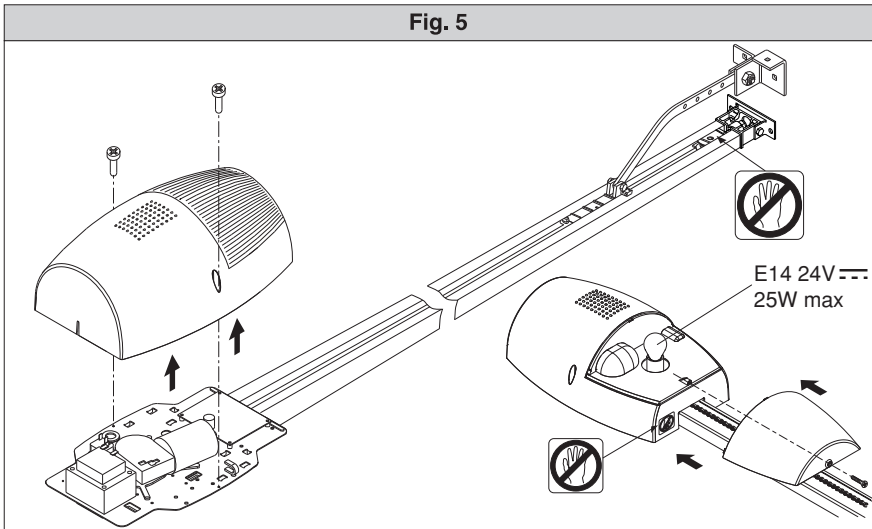
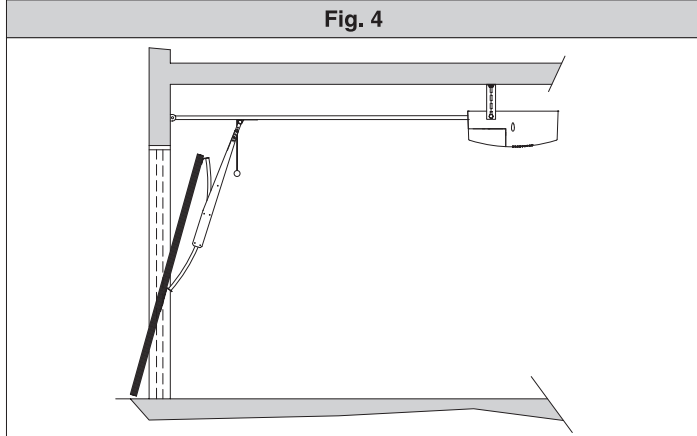
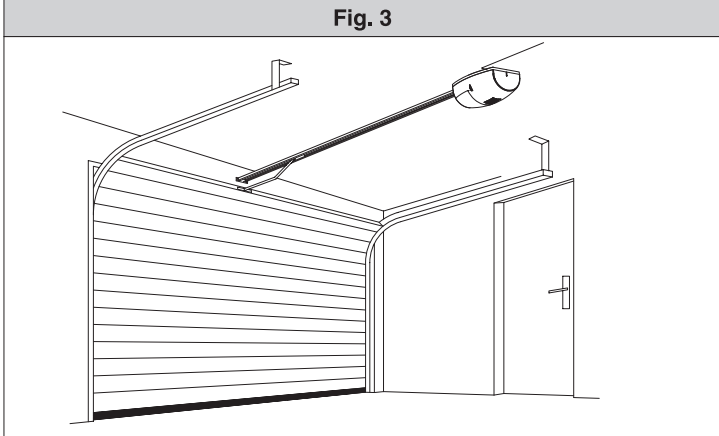
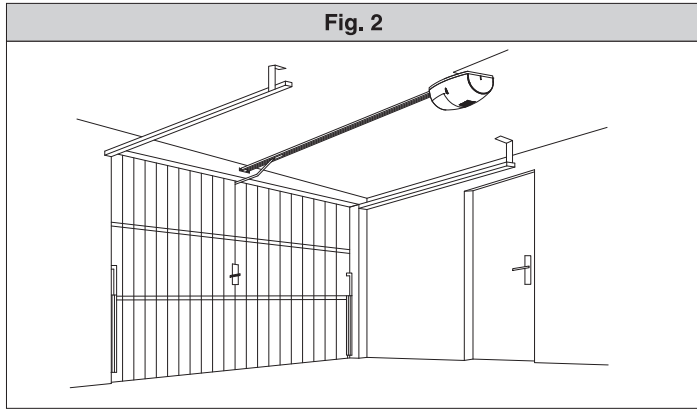
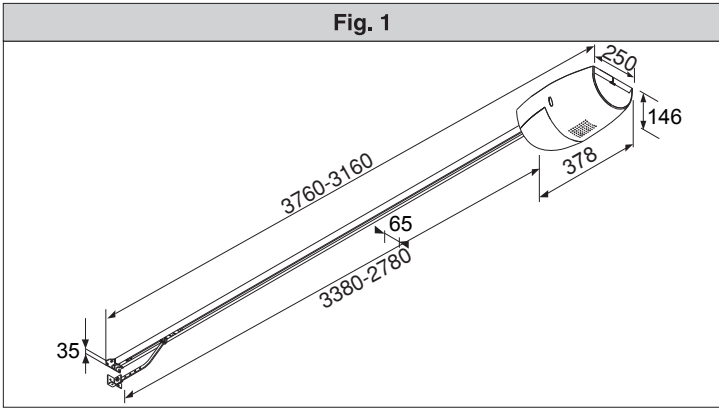


Fig. B





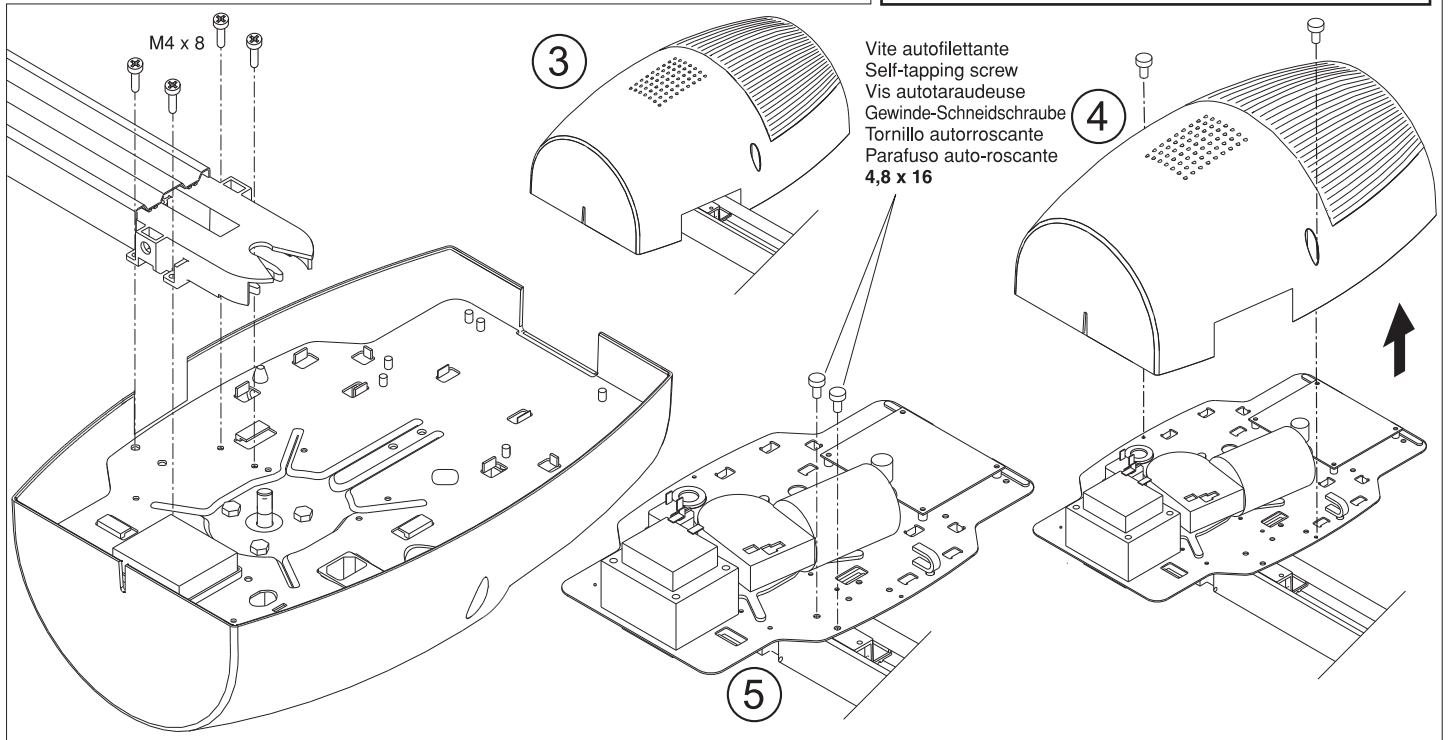
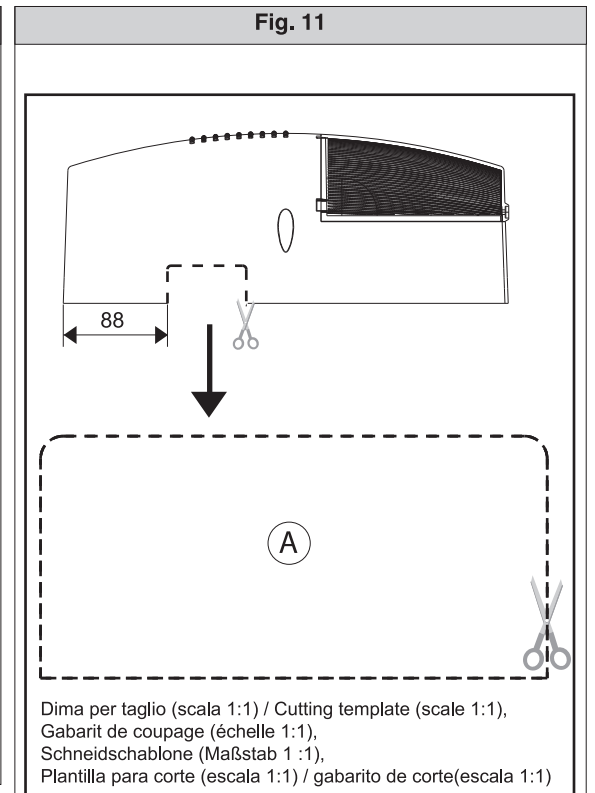
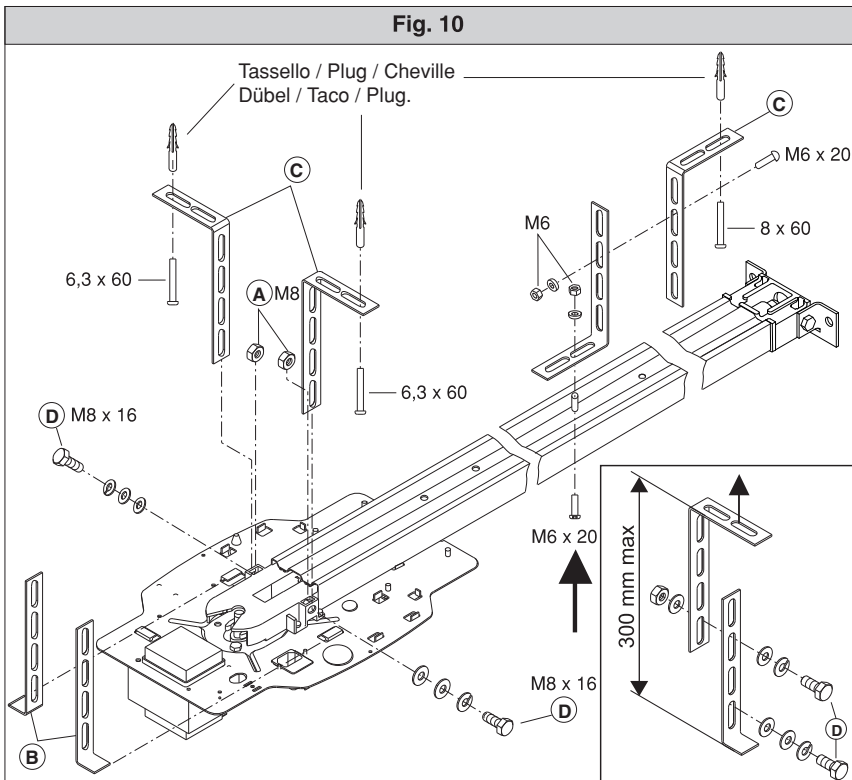
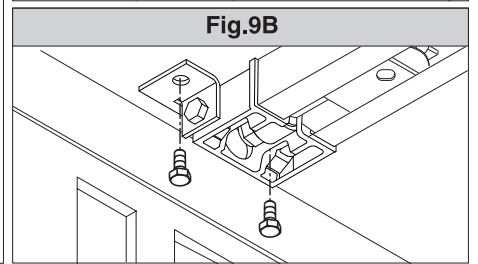
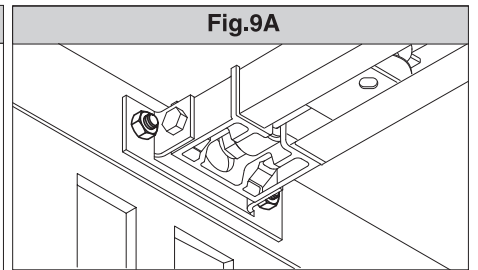
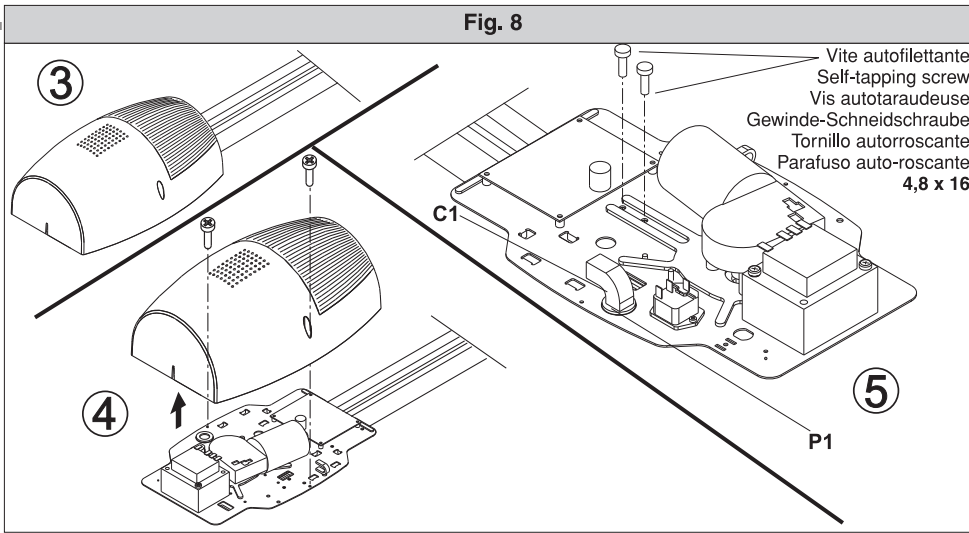


Fig.12

Tassello / Plug / Cheville
Dübel / Taco / Plug.

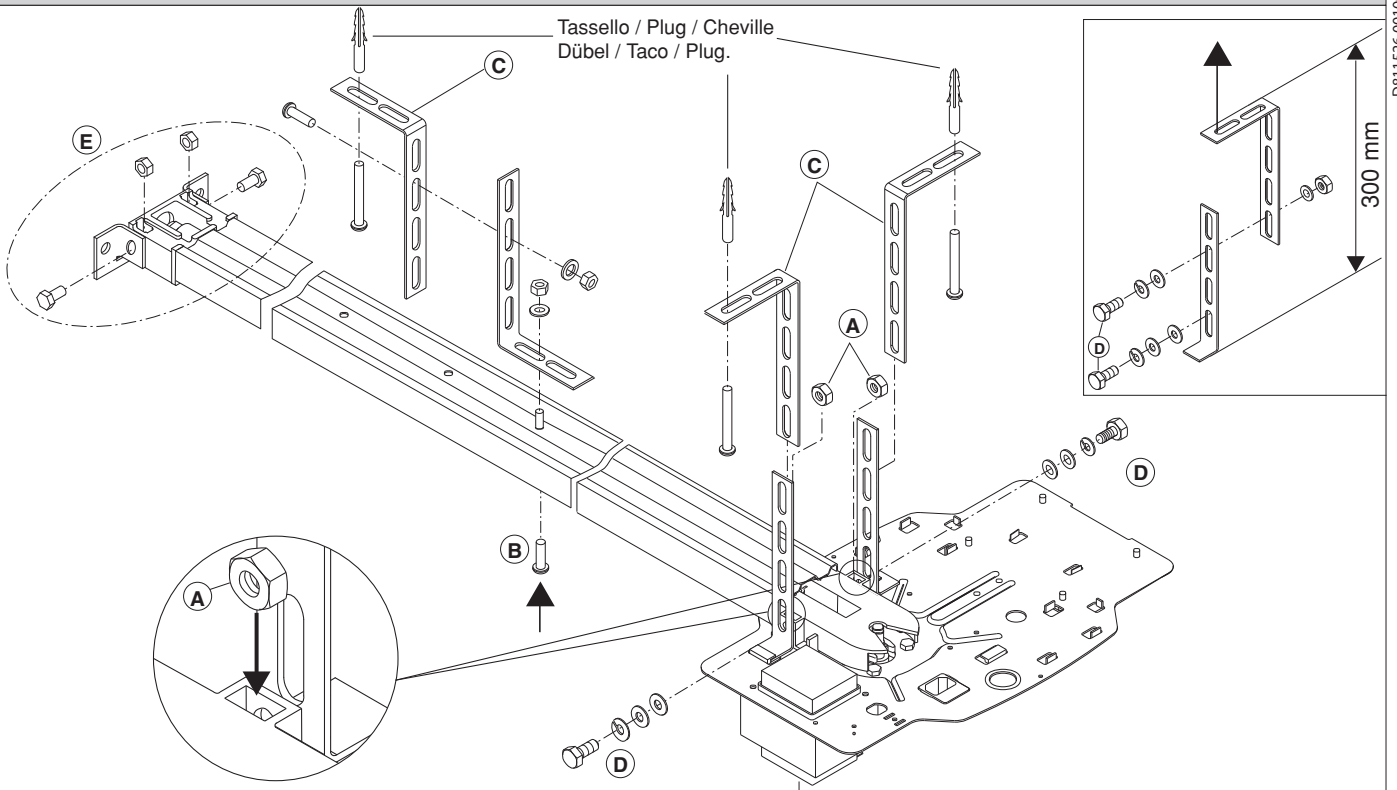


Fig.13

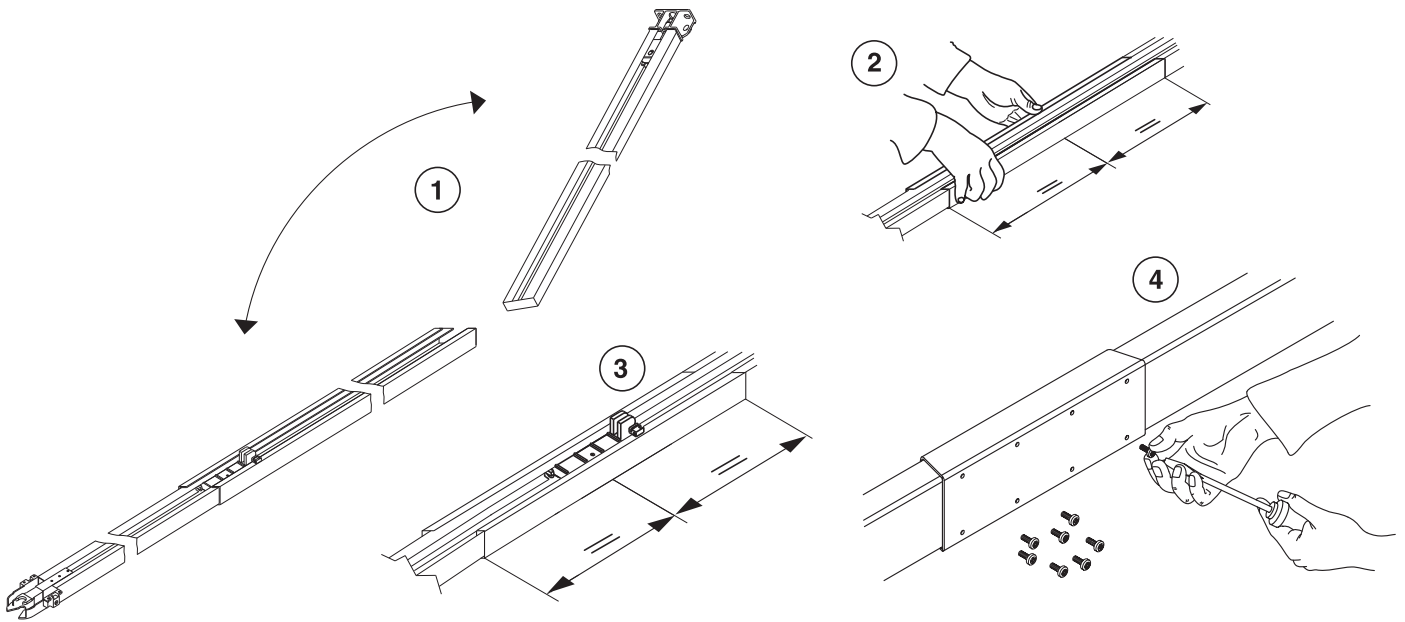


Fig.14

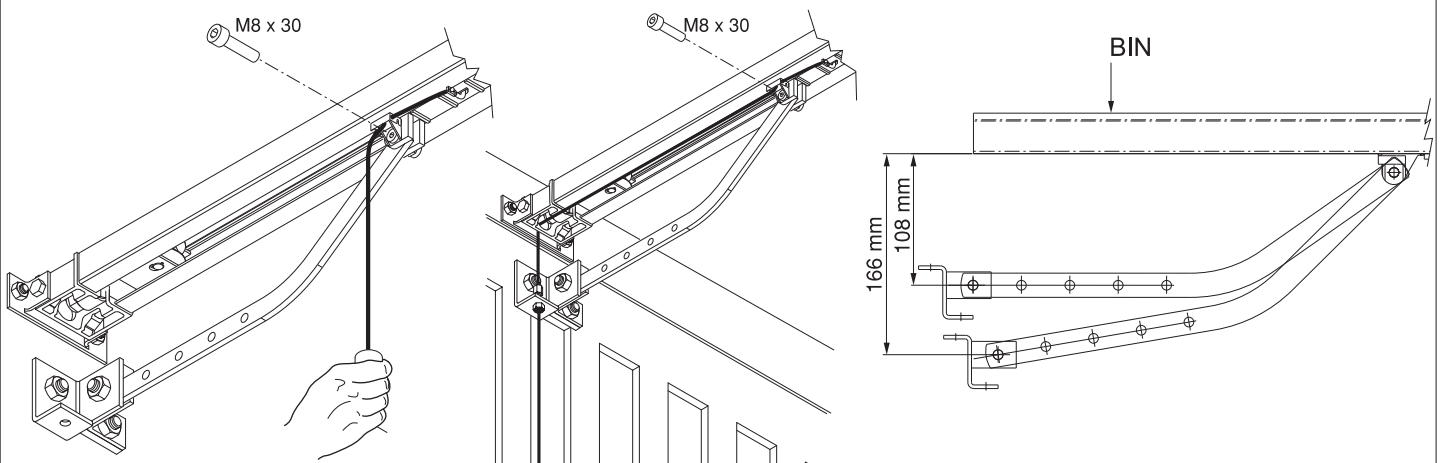


Fig.15

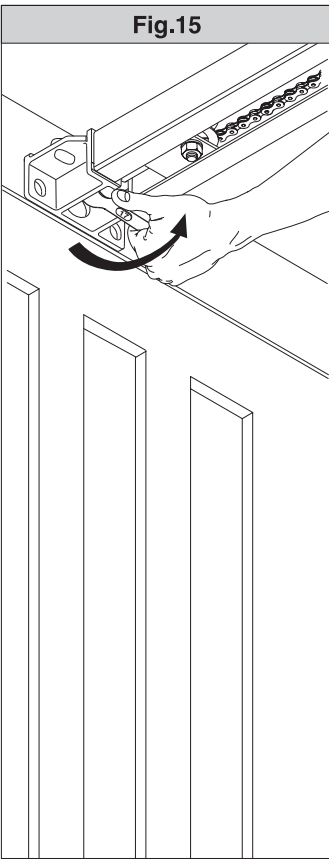
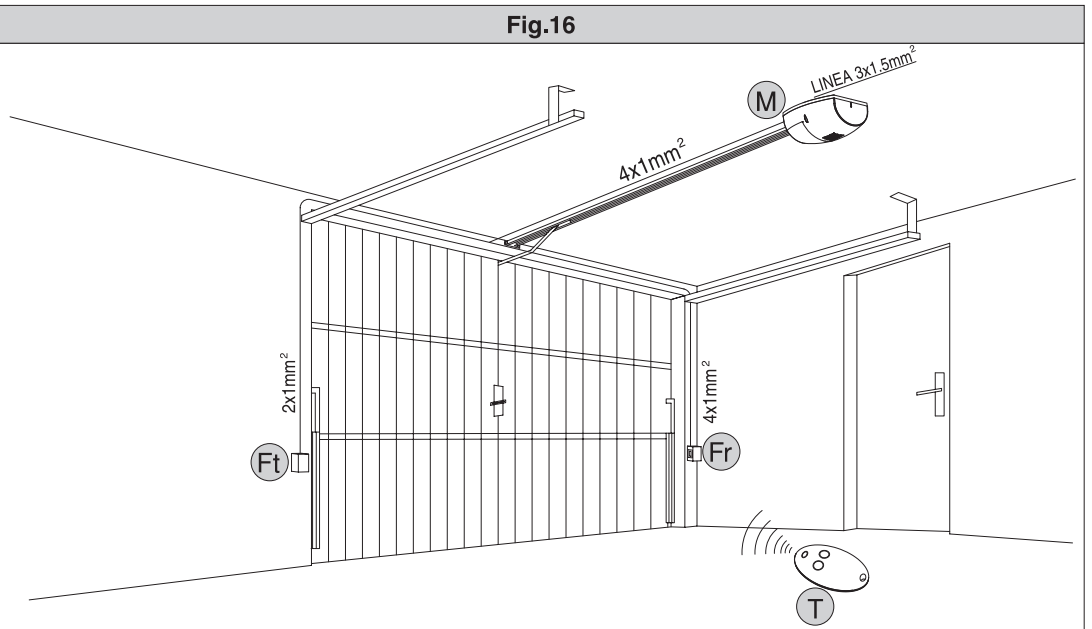


Fig.16



Eventuali passaggi per cavi,
Possible cable passages,
Passages éventuels pour les câbles,
Eventuelle Kabelführungen,
Eventuales accesos para cables,
Eventuais passagens para cabos.

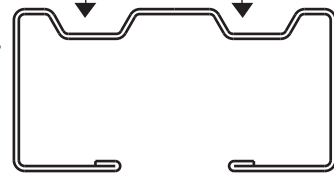
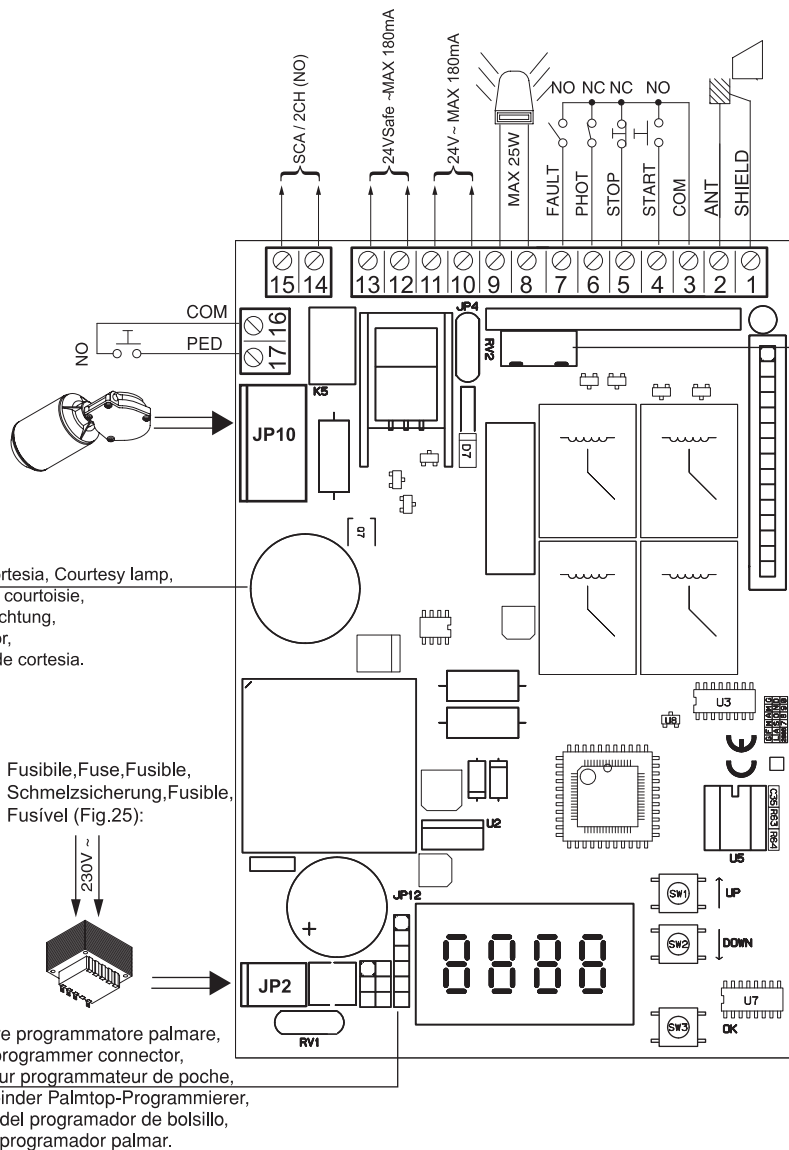
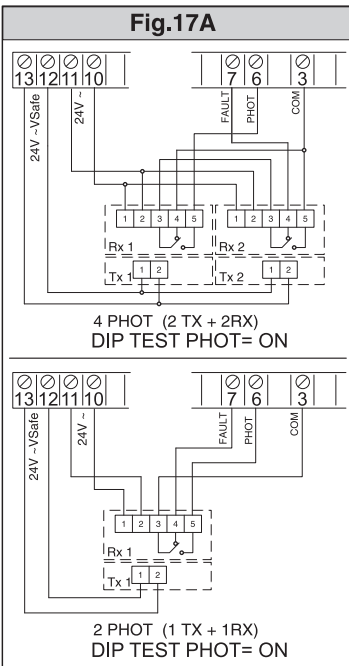


Fig.17

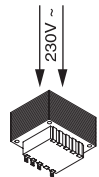
Fig.17A



Connettore scheda opzionale (SCS1)
SCS1 optional board connector
Connecteur carte facultative SCS1
Steckverbinder Zusatzkarte SCS1
Conector de la tarjeta opcional (SCS1)
Conector placa opcional SCS1

Luce di cortesia, Courtesy lamp,
Lampe de courtoisie,
Hilfsbeleuchtung,
Luz interior,
Împada de cortesia.

Fusibile, Fuse, Fusible,
Schmelzsicherung, Fusible,
Fusivel (Fig.25):



Connettore programmatore palmare,
Palmtop programmer connector,
Connecteur programmeur de poche,
Steckverbinder Palmtop-Programmierer,
Conector del programador de bolsillo,
Conector programador palmar.

Fig. 18

D811526 00100_02

REGOLAZIONE FINECORSO, LIMIT DEVICE SETTING, ÉGLAGE FIN DE COURSE, EINSTELLUNG DER ENDSCHALTER, REGULACION DEL GRUPO DE FIN DE CARRERA, REGULAÇÃO DO FIM-DE-CURSO.

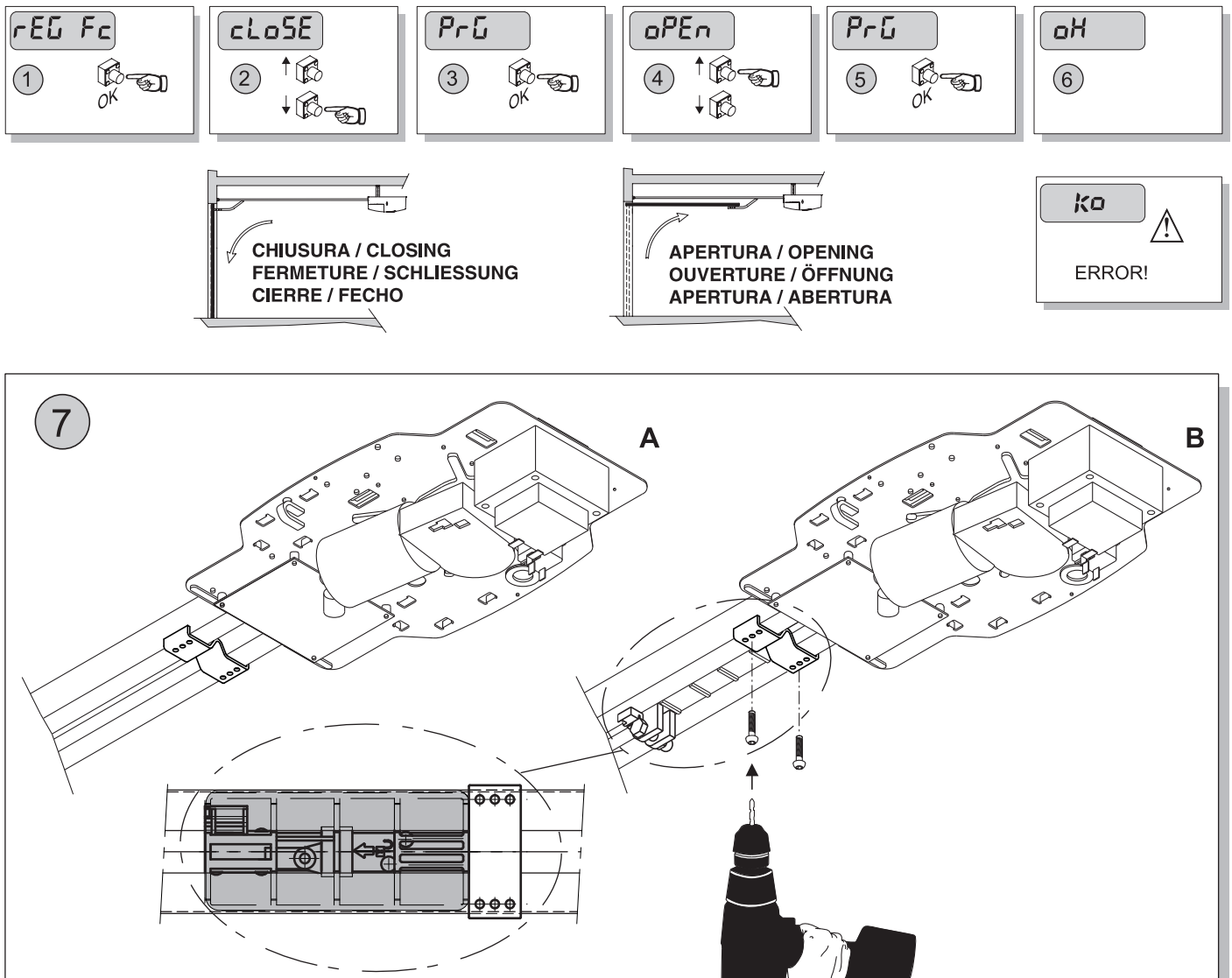


Fig. 19

AUTOSET COPPIA APERTURA / CHIUSURA, OPENING / CLOSING TORQUE AUTOSETTING, RÉGLAGE AUTOMATIQUE COUPLE OUVERTURE / FERMETURE, AUTOSET DREHMOMENT ÖFFNUNG / SCHLISSUNG, AJUSTE AUTOMATICO DEL PAR EN FASE DE APERTURA / CIERRE, AUTOSET BINÁRIO DE ABERTURA / FECHO.

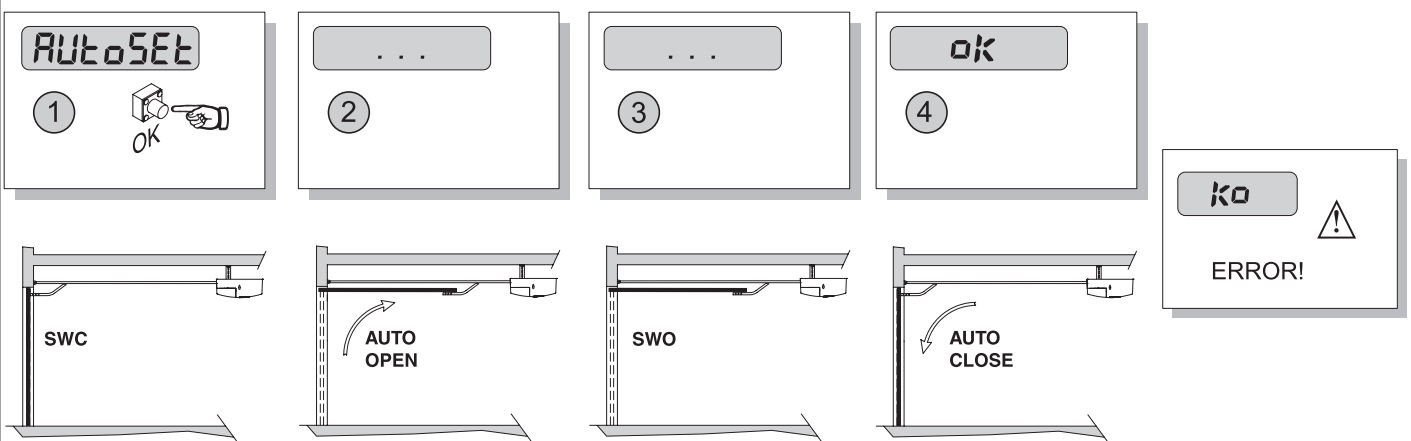


Fig. 20

PROGRAMMAZIONE TRASMETTITORI REMOTA, REMOTE TRANSMITTER PROGRAMMING, PROGRAMMATION ÉMETTEURS A DISTANCE, FERNPROGRAMMIERUNG DER SENDER, PROGRAMACION DE TRANSMISORES REMOTA, PROGRAMAÇÃO REMOTA DOS TRANSMISSORES.


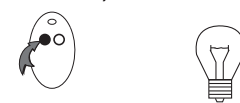


<p>1 Radiocomando già memorizzato Radio transmitter already memorised Radiocommande déjà mémorisée Bereits gespeicherte Funksteuerung Radiomando ya memorizado Radiocomando já memorizado</p> 	<p>2 Radiocomando già memorizzato Radio transmitter already memorised Radiocommande déjà mémorisée Bereits gespeicherte Funksteuerung Radiomando ya memorizado Radiocomando já memorizado</p> 	<p>3 Radiocomando da memorizzare Radio transmitter to memorise Radiocommande à mémoriser Zu speichernde Funksteuerung Radiomando que memorizar Radiocomando a memorizar</p> 	<p>4 Radiocomando da memorizzare Radio transmitter to memorise Radiocommande à mémoriser Zu speichernde Funksteuerung Radiomando que memorizar Radiocomando a memorizar</p> 
--	--	---	--

Fig. 20A

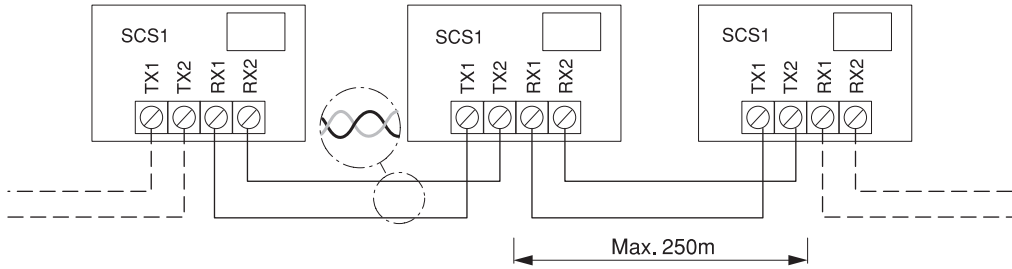


Fig. 21

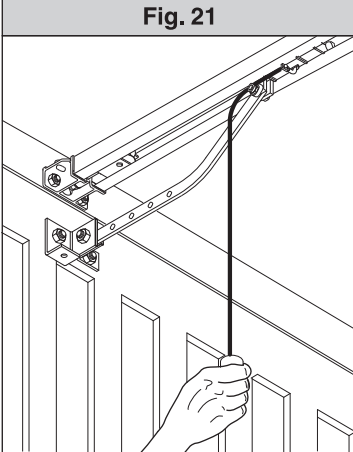


Fig. 22

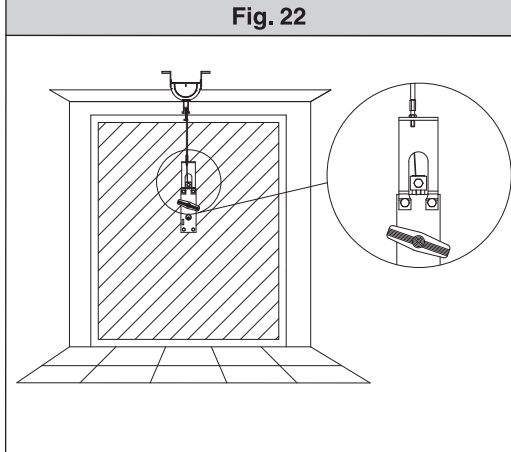


Fig. 23

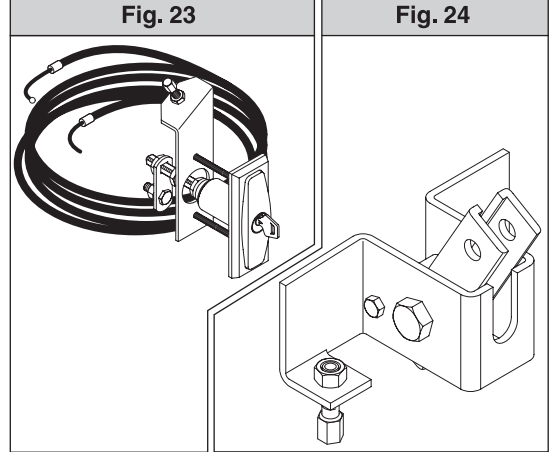


Fig. 24

Fig. 25

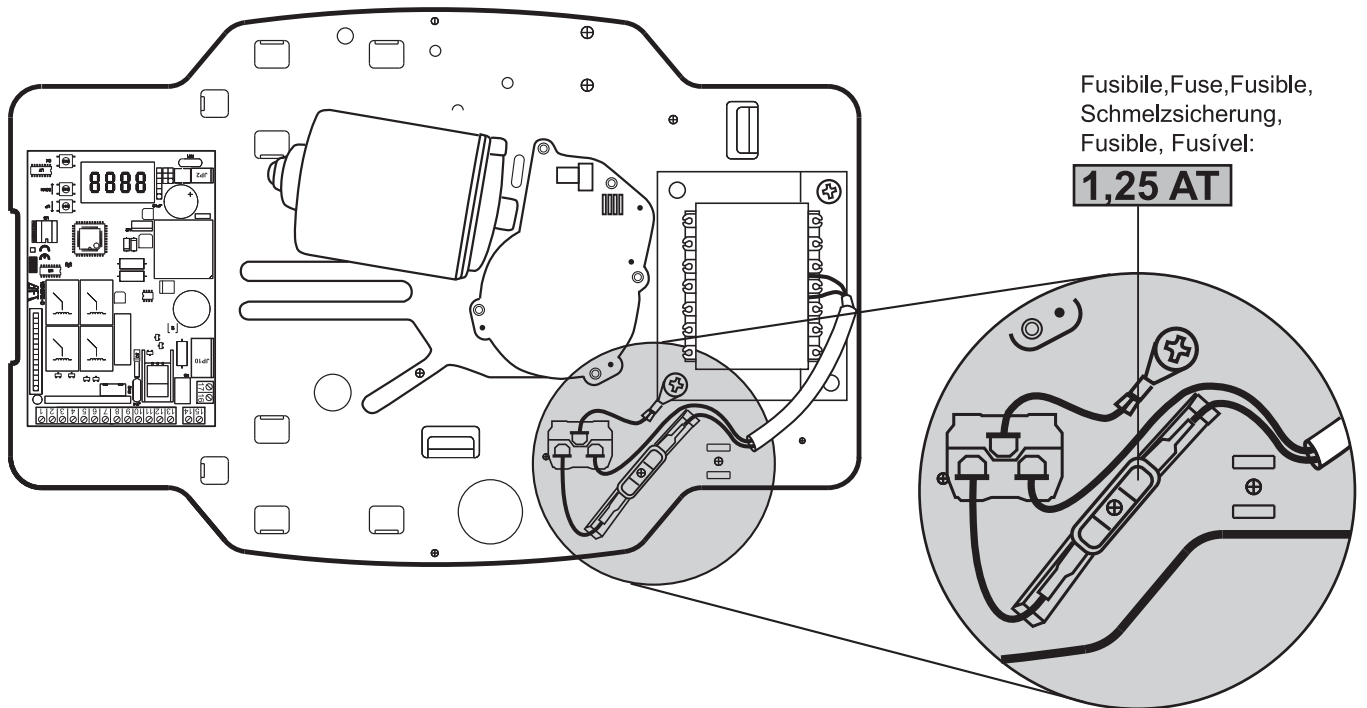


Fig. 26

Montaggio tappi per operatore EOS 120 VENERE D - Assembly of caps for EOS 120 VENERE D operator - Montage bouchons pour opérateur EOS 120 VENERE D - Montage der Stopfen für Antrieb EOS 120 VENERE D - Montaje topones para automatizacio'n EOS 120 VENERE D - Montage doppen voor aandrijving EOS 120 VENERE D.

D811526 00100_02

